

## VT67BB W - B10 - B10 - 1 R 00 - A 1 - M1 -

Series- SAE B 2 bolts  
Mounting flange J744c

Use for severe duty shaft only

Cam ring for "P1" and "P2"

Volumetric displacement  $\text{cm}^3/\text{rev}$  ( $\text{in}^3/\text{rev}$ )

B02 = 5.8 (0.35)	B09 = 28.0 (1.71)
B03 = 9.8 (0.60)	B10 = 31.8 (1.94)
B04 = 12.8 (0.78)	B11 = 34.9 (2.13)
B05 = 15.9 (0.97)	B12 = 40.9 (2.50)
B06 = 19.8 (1.21)	B14 = 45.1 (2.75)
B07 = 22.5 (1.37)	B15 = 50.0 (3.05)
B08 = 24.9 (1.52)	

Type of shaft

- 1 - keyed (no SAE)
- 3 - splined (SAE BB)
- 5 - splined (SAE B)

Type of shaft- W version

- 2 - keyed (SAE BB)

Modifications

Mounting W/connection variables

- 11 = 4 bolts SAE flanges (J518c) UNC thread
- M1 = 4 bolts SAE flanges (J518c) Metric thread

Seal class

- 1 - S1 (for mineral oil)
- 4 - S4 (for fire resistant fluids)
- 5 - S5 (for mineral oil and fire resistant fluids)

Design letter

Porting combination (see page BM-1-5)

00 - standard

Direction of rotation (view on shaft end)

- R - clockwise
- L - counter-clockwise

### INTERNAL LEAKAGE ( TYPICAL )

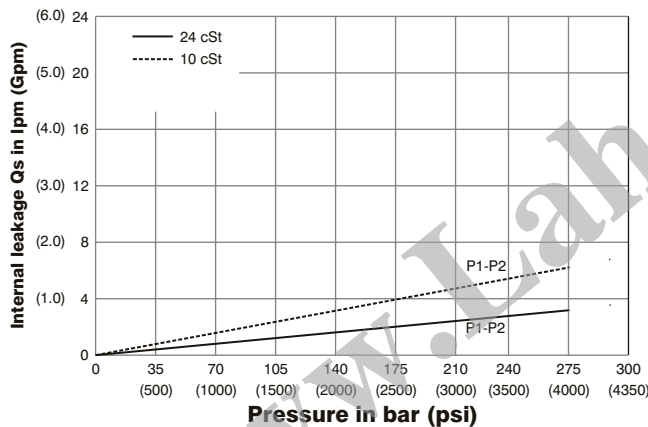

Do not operate pump more than 5 seconds at any speed or viscosity if internal leakage is more than 50% of theoretical flow.  
Total leakage is the sum of each section loss at its operating conditions.

### NOISE LEVEL ( TYPICAL ) VT67BB- B10-B03

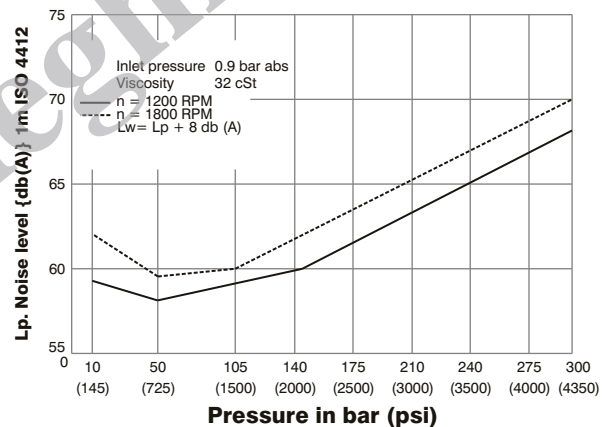

Double pump noise level is given with each section discharging at the pressure noted on the curve.

### HYDROMECHANICAL POWER LOSS ( TYPICAL )

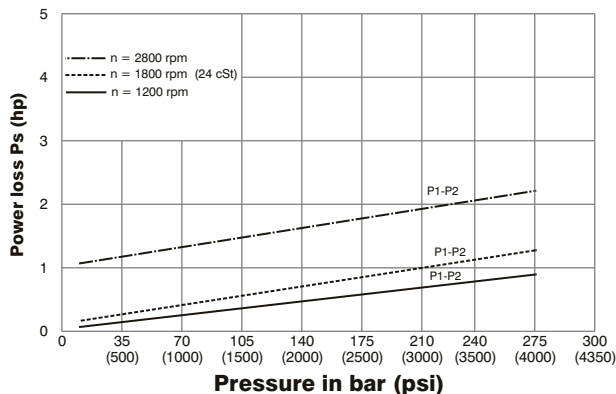

Total hydromechanical power loss is the sum of each section at its operating conditions.

### PERMISSIBLE RADIAL LOAD

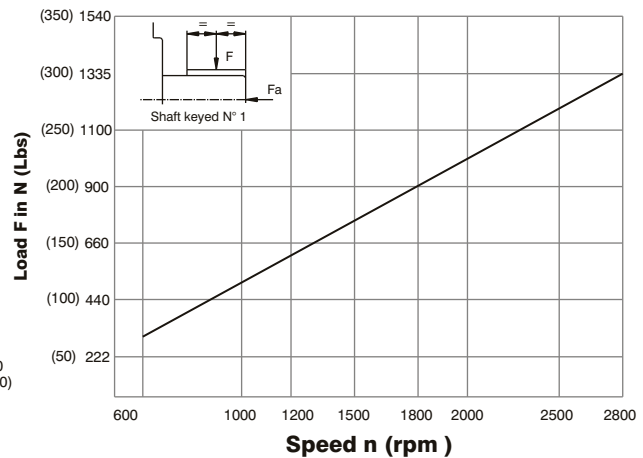

Maximum permissible axial load  $F_a = 800\text{N}$  (180 lbs)

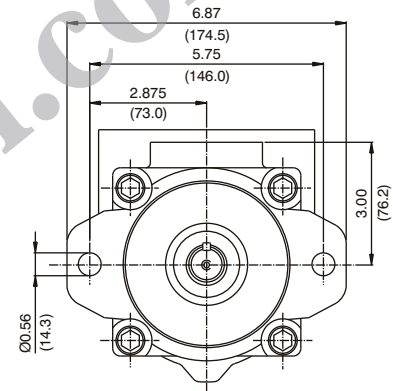
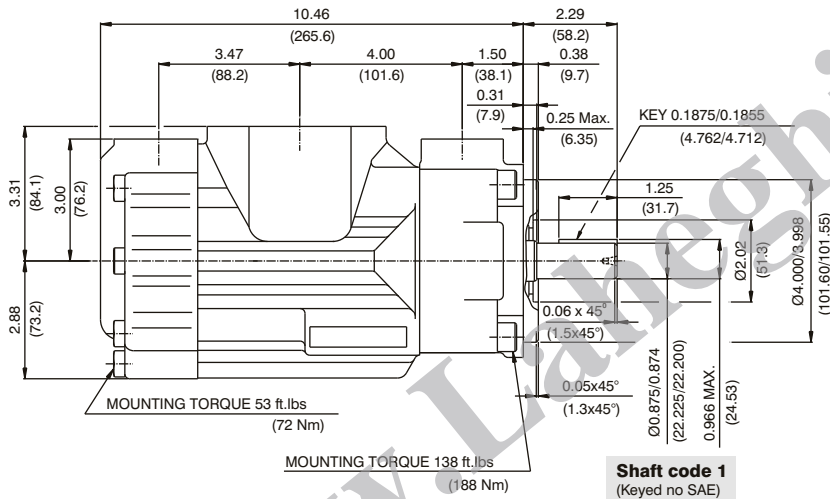
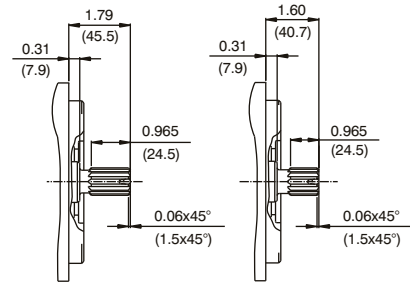
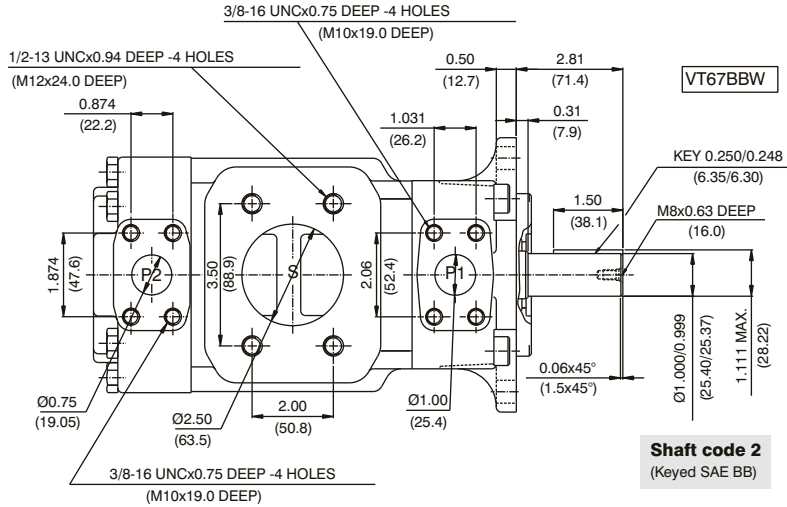

Shaft torque limits in <sup>3</sup> /rev x psi (ml/rev x bar)	
Shaft	Vp x p max. (P1+P2)
1	12666 (14300)
2	18972 (21420)
3	28937 (32670)
5	18246 (20600)

Pressure port	Series	Volumetric Displacement Vp		Flow q & n = 1800 rpm						Input power p & n = 1800 rpm					
		in <sup>3</sup> /rev		p = 0 bar (0 psi)		p = 140 bar (2000 psi)		p = 300 bar (4350 psi)		p = 7 bar (100 psi)		p = 140 bar (2000 psi)		p = 300 bar (4350 psi)	
		cm <sup>3</sup> /rev	gpm	lpm	gpm	lpm	gpm	lpm	gpm	lpm	hp	kw	hp	kw	hp
P1 & P2	B02	0.35	5.7	2.76	10.4	2.33	8.8	1.80	6.8	0.74	0.55	4.02	2.99	8.10	6.40
	B03	0.60	9.8	4.66	17.6	4.23	15.9	3.70	14.0	0.85	0.63	6.24	4.65	12.93	10.25
	B04	0.78	12.8	6.09	23.0	5.66	21.4	5.13	19.4	0.94	0.70	7.90	5.89	16.55	13.13
	B05	0.97	15.9	7.56	28.6	7.13	26.9	6.60	25.0	1.02	0.76	9.62	7.17	20.29	16.12
	B06	1.21	19.8	9.42	35.6	8.99	33.9	8.46	32.0	1.13	0.84	11.79	8.79	25.00	19.88
	B07	1.37	22.5	10.70	40.4	10.27	38.8	9.74	36.8	1.20	0.89	13.29	9.91	28.26	22.47
	B08	1.52	24.9	11.84	44.7	11.41	43.1	10.88	41.1	1.27	0.94	14.62	10.90	31.15	24.78
	B09	1.71	28.0	13.31	50.3	12.87	48.6	12.35	47.0	1.36	1.01	16.35	12.19	34.92	27.77
	B10	1.94	31.8	15.12	57.2	14.69	55.5	14.16	53.5	1.46	1.11	18.45	13.75	39.48	31.42
	B11 <sup>1)</sup>	2.13	34.9	16.64	62.9	16.19	61.2	15.68	59.3	1.55	1.15	20.17	15.04	43.22	32.22
	B12 <sup>1)</sup>	2.50	40.9	19.50	73.7	19.07	72.1	18.54	70.1	1.72	1.28	23.55	17.56	50.58	37.71
	B14 <sup>1)</sup>	2.75	45.1	21.40	80.8	20.95	79.2	20.44	77.0	1.83	1.36	25.80	19.23	55.48	41.37
	B15 <sup>1)</sup>	3.05	50.0	23.78	89.8	23.35	88.3	22.88	86.5	1.97	1.47	28.55	21.28	57.35	42.7

1) B11-B12-B14 = 300 bar (4350 psi) & B15 = 280 bar (4060 psi) max. int. And Max. Speed = 3000 rpm